

Multimatic Welding Cart Instructions.

Please read these instructions thoroughly before welding your cart. If you need further instruction you can download the 3D models by visiting the "Instructions and 3D models" page on All-a-cart.com

Proper PPE is recommended at all times. Safety glasses, gloves, hearing protection, and/or a welding helmet when necessary. Sheet metal edges may be sharp. Handle with caution.

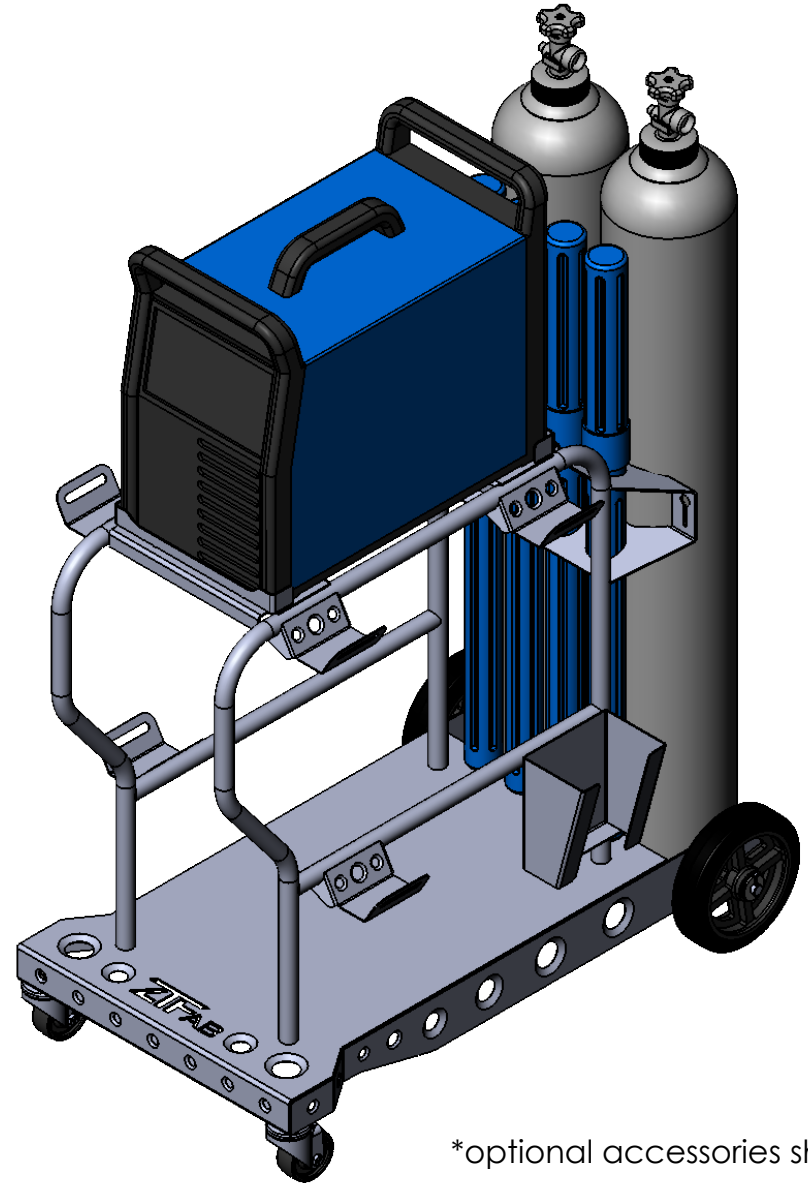

*optional accessories shown

WC-M220

Updated 4/20

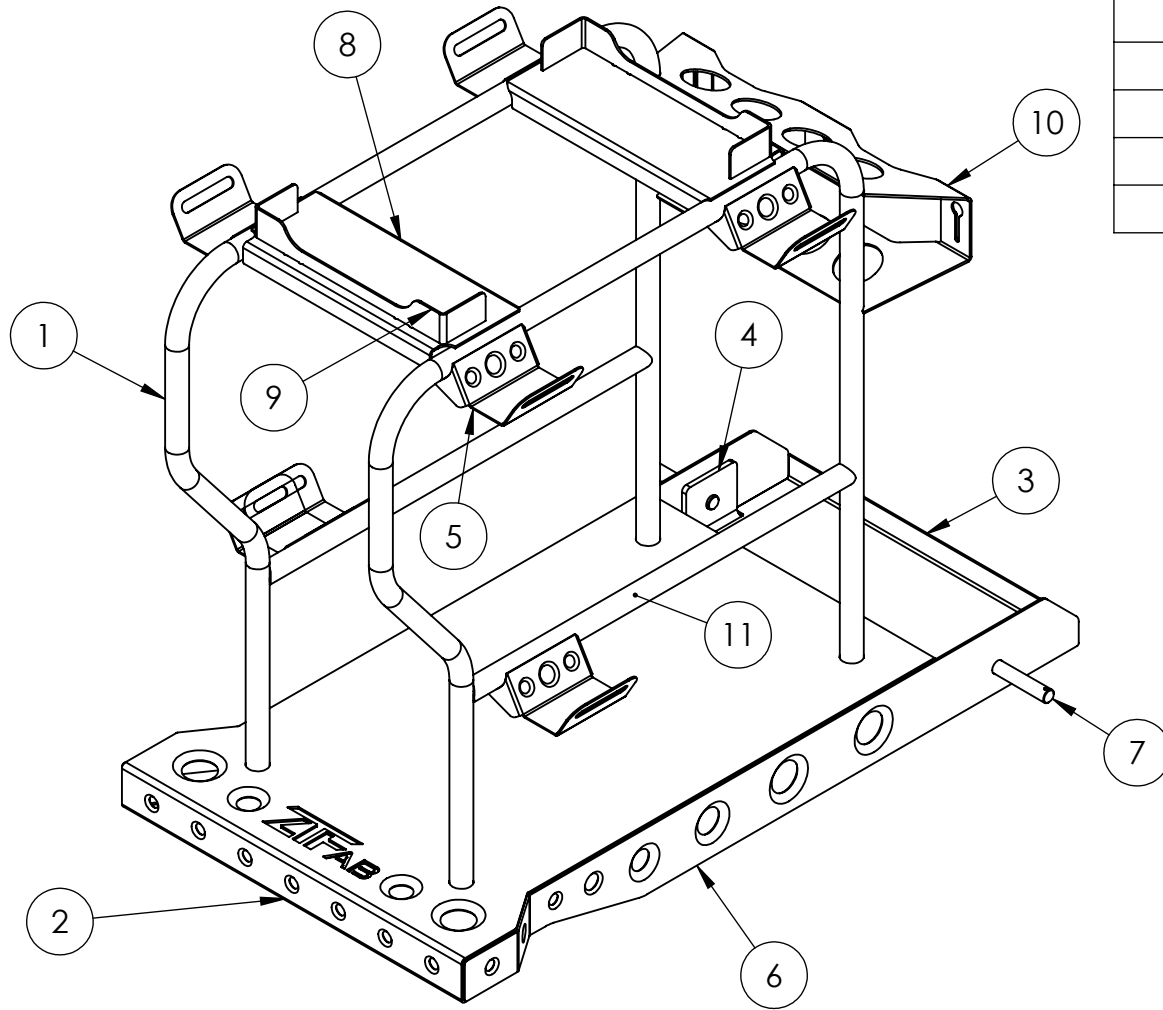

ITEM NO.	PART NUMBER	Standard/Default/QTY.
1	WC-Handle Tube	2
2	WC-Base	1
3	WC-Bottle Base	1
4	WC-Axle Bracket	1
5	WC-Cord Hangers	6
6	WC-Sides	2
7	WC-Axle Shaft	2
8	Mount Base	2
9	U-Bracket	2
10	WC-Bottle Bracket	1
11	Accessory Tubes	2

NOTE: For optimal results it is recommended that all areas requiring welding be cleaned by lightly sanding with sand paper or scotch brite pads. Clean, shiny metal welds the best.

Step 1: Base Sides

Position Side plates onto cart base.
A square or 90* corner magnets will
help in lining up the edges.

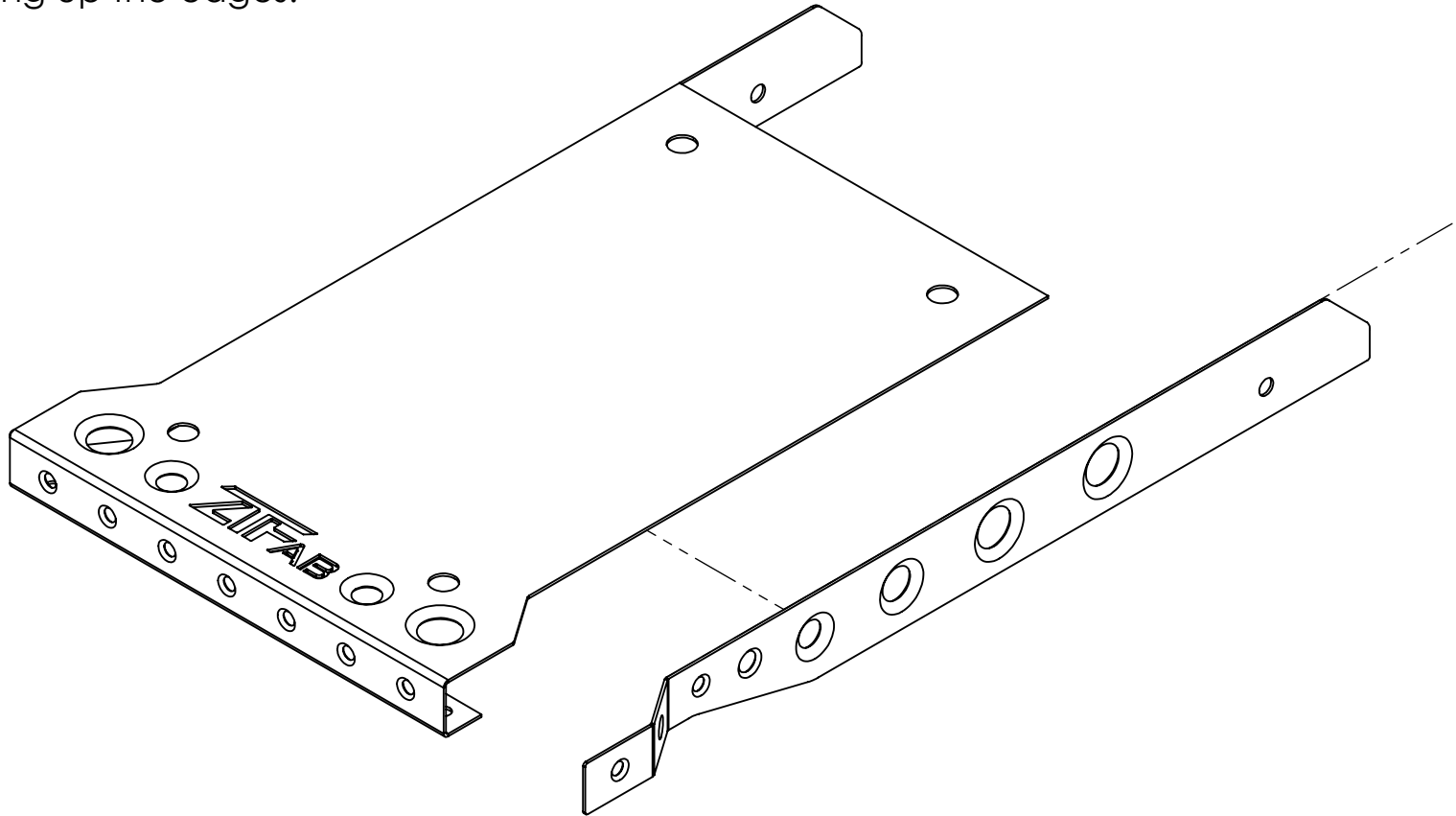

Note:

**Lightly Sand all edges that need to be welded
for best quality. Being careful not to remove
excessive material.**

Step 1A:

Tack weld sides to base incrementally to ensure proper corner fit-up. Position tack welds every 2-3 inches to help keep distortion to a minimum. Sides should be 90° to the top of the cart base.

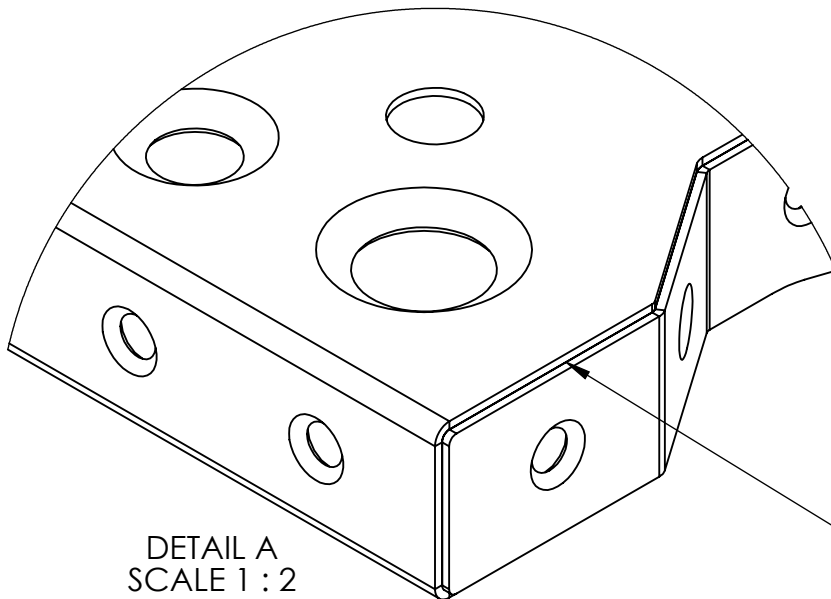
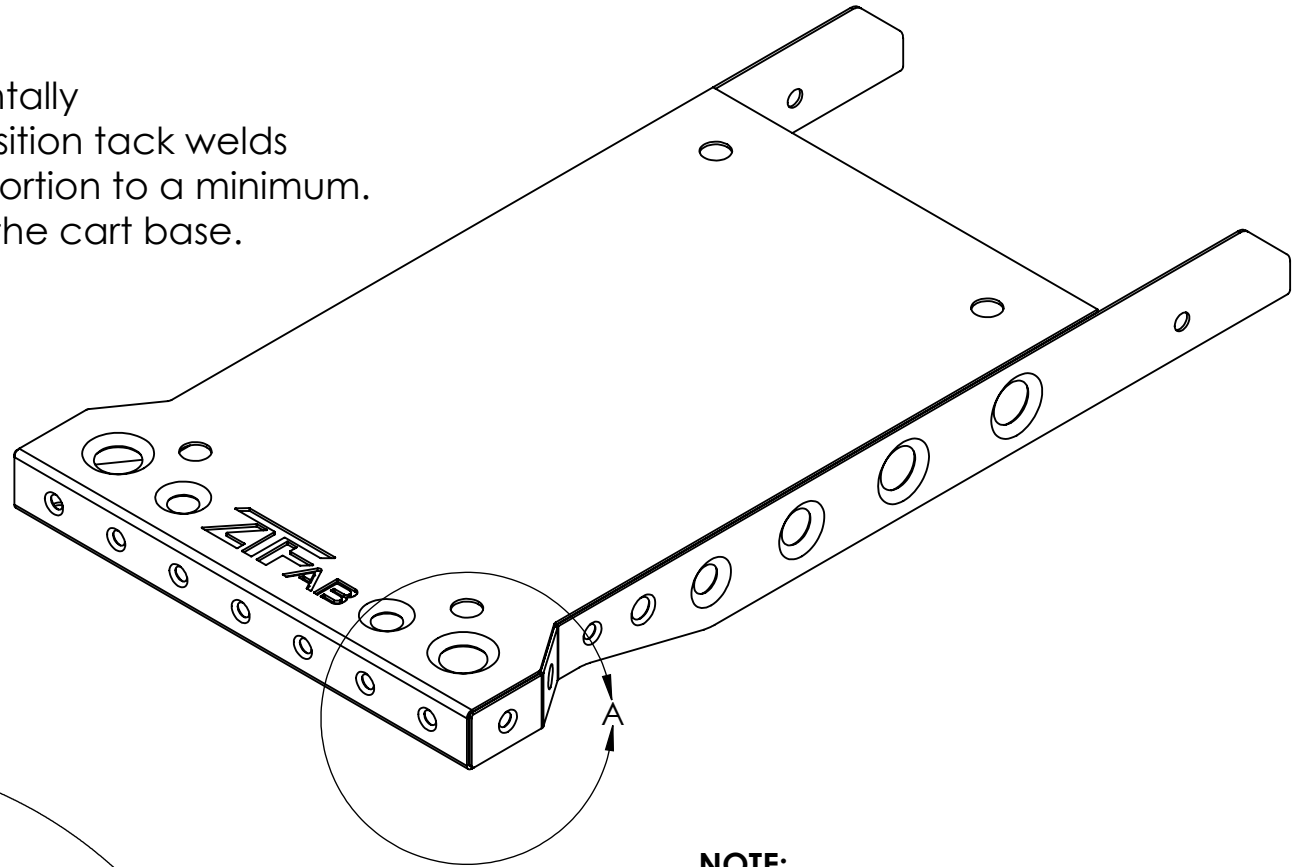

DETAIL A
SCALE 1 : 2

NOTE:
Due to the Dimple Die Forming of the side panels they may be slightly curved. It may be easiest to start with the front corner, position and tack weld it first, then use a large clamp or clamps and work your way to the back, aligning, fitting, and tacking along the way.

Fit-up should be an "Open Corner" joint.

Step 2: Bottle Base

Fit Bottle Base to sides and cart base.
Tack weld once properly fit-up.

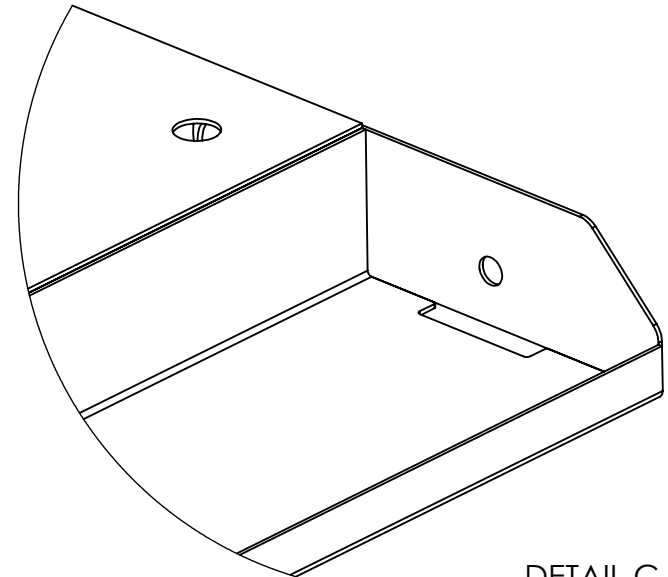
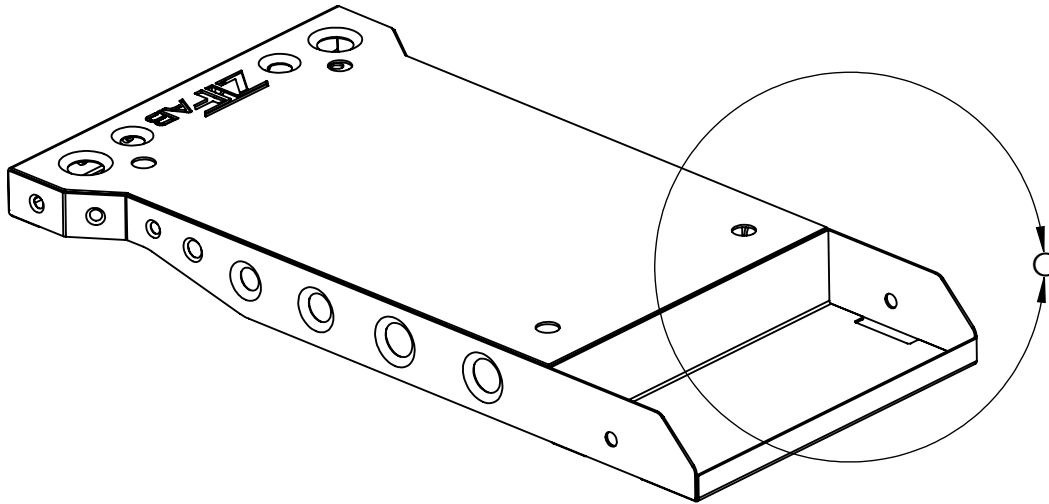
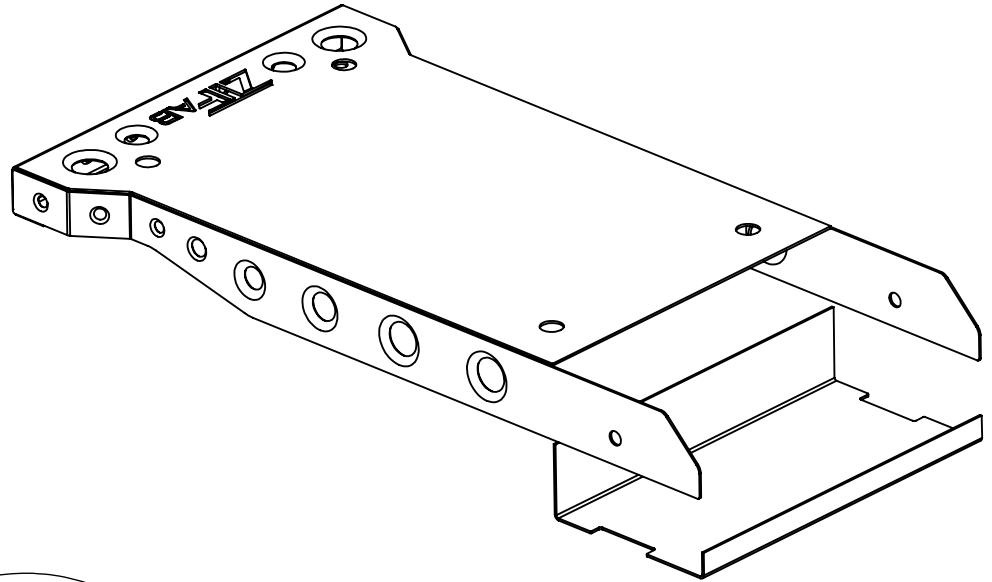

DETAIL C
SCALE 1 : 4

Step 3: Axle Bracket

Position the axle bracket into the slots of the bottle base. Align the axle holes and tack weld into place.
TIP: Use the axle shafts or some bolts to keep the holes aligned.

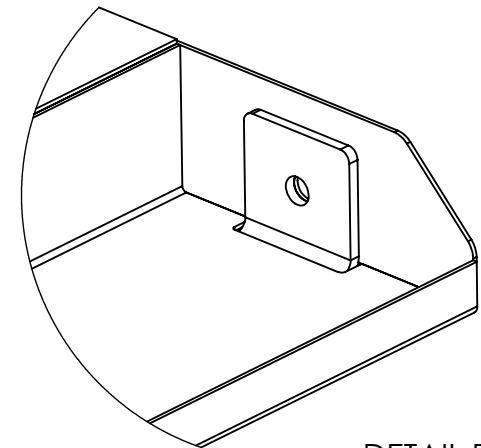
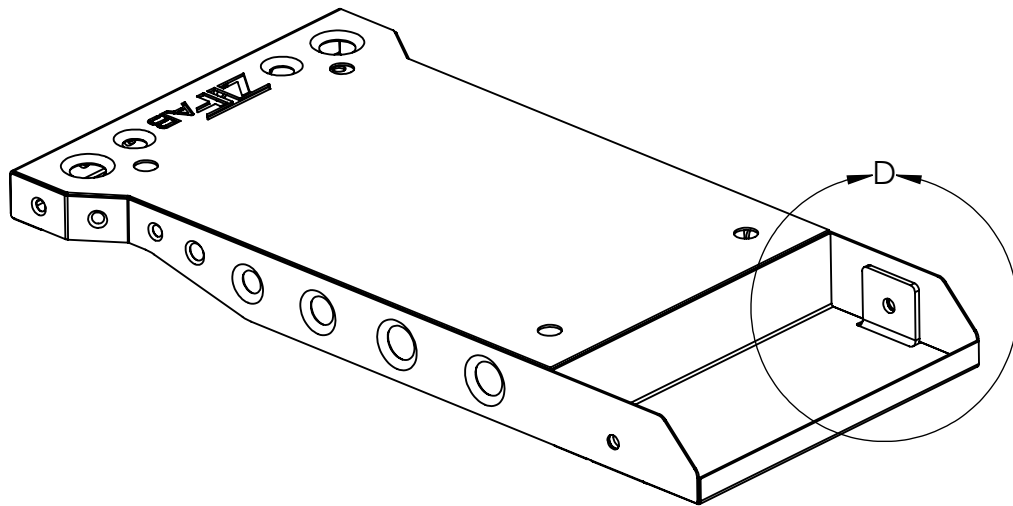
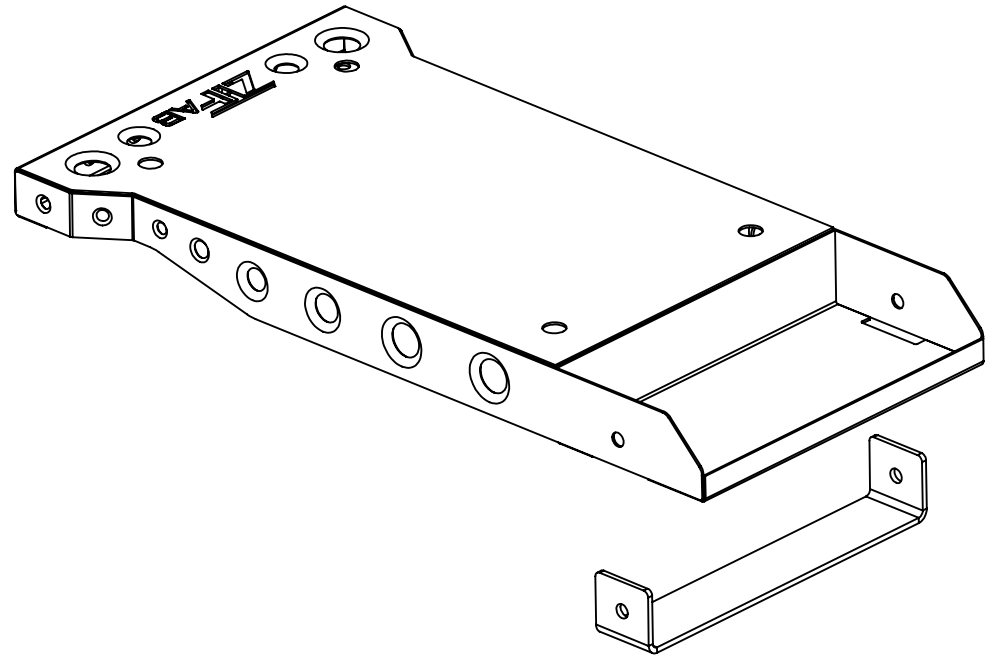

DETAIL D
SCALE 1 : 4

Step 4: Welding the Base

Weld the parts of the base together using your preferred method of welding (MIG or TIG). Alternate your welds to keep distortion to a minimum.

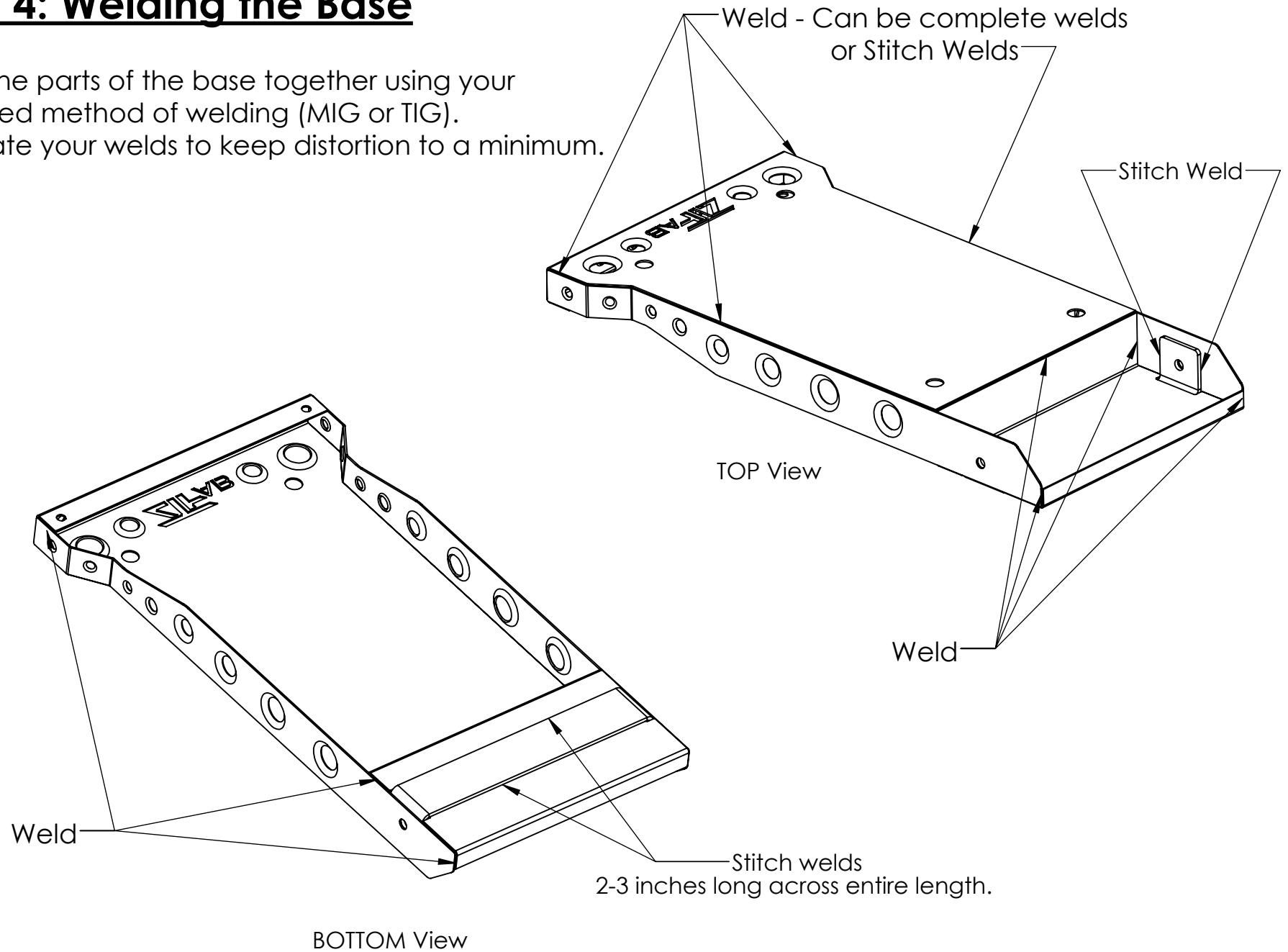

Step 5: Positioning Tubes

Insert Handle tubes into the pre-cut holes in the cart base. Tubes should fit flush to the bottom of the plate.

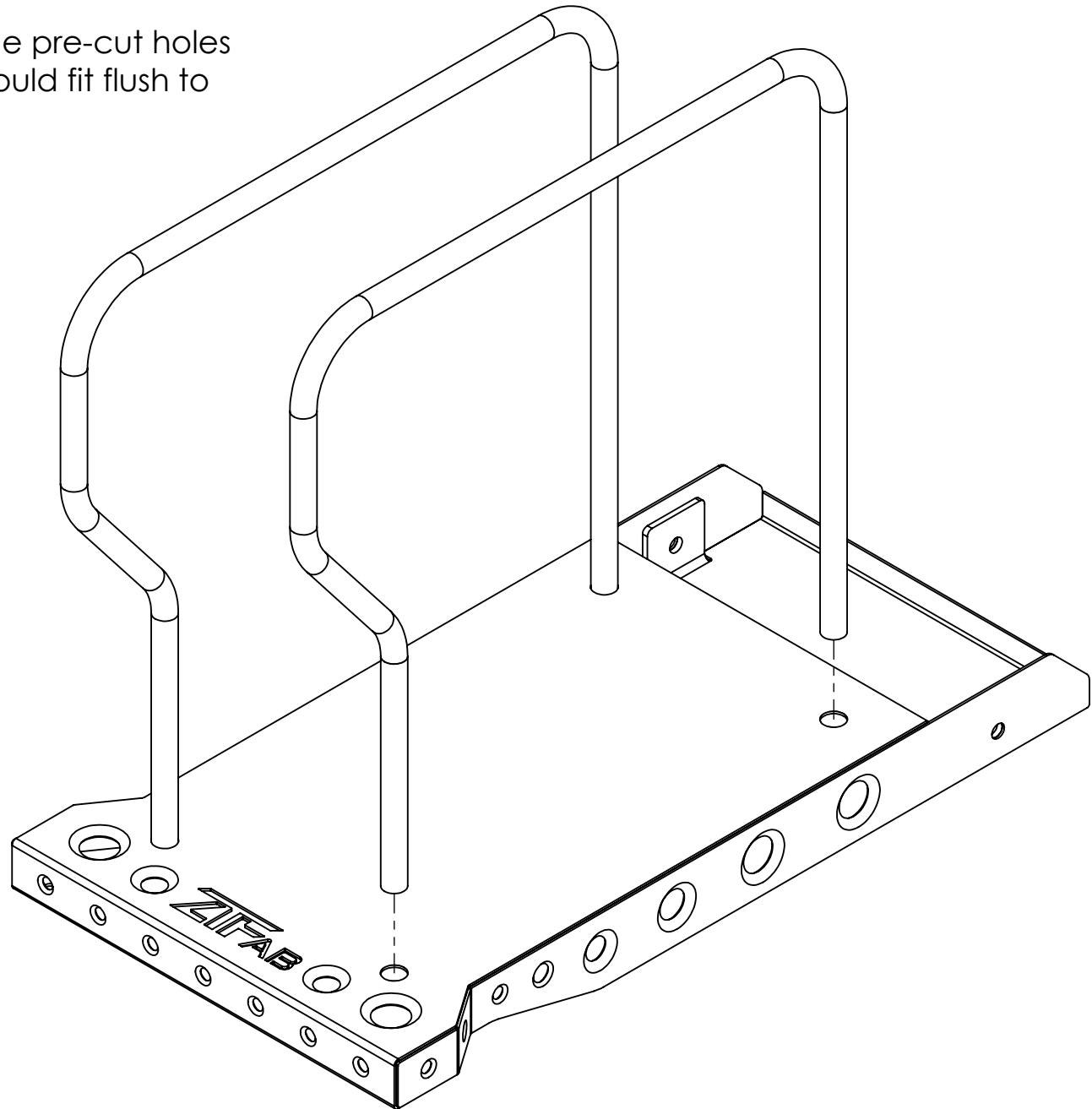

Step 5A: Tacking Tubes

Ensure that tubes are 90° to the base and parallel to each other. Then tack weld into position.

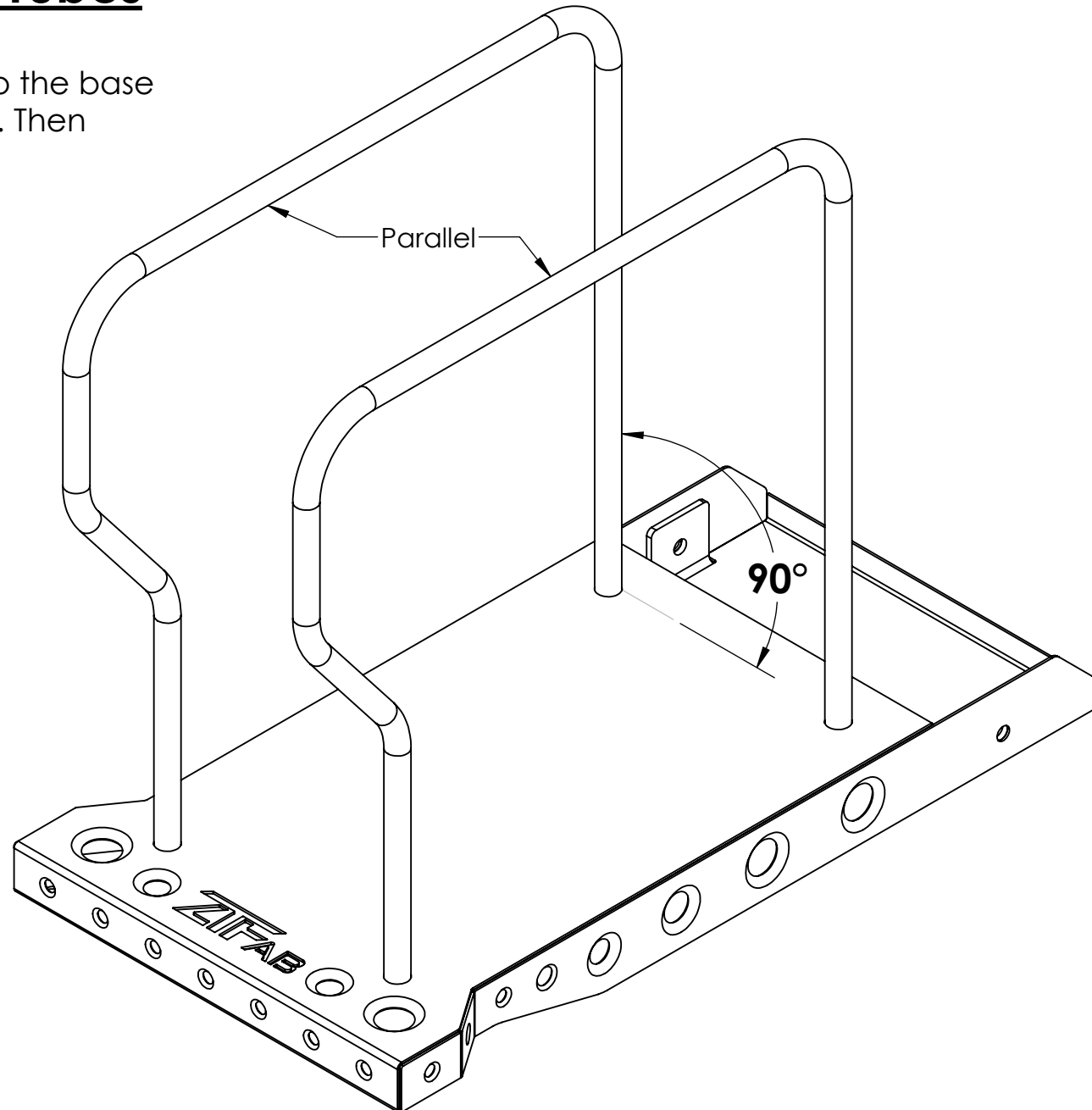

Step 6: Bottle Bracket

Position the Bottle Bracket onto the tubes. Height of the bracket will be determined by the size of your bottles. Pay close attention to the orientation of the chain slots. Make sure the Large opening is at the top. Tack weld the bracket in place.

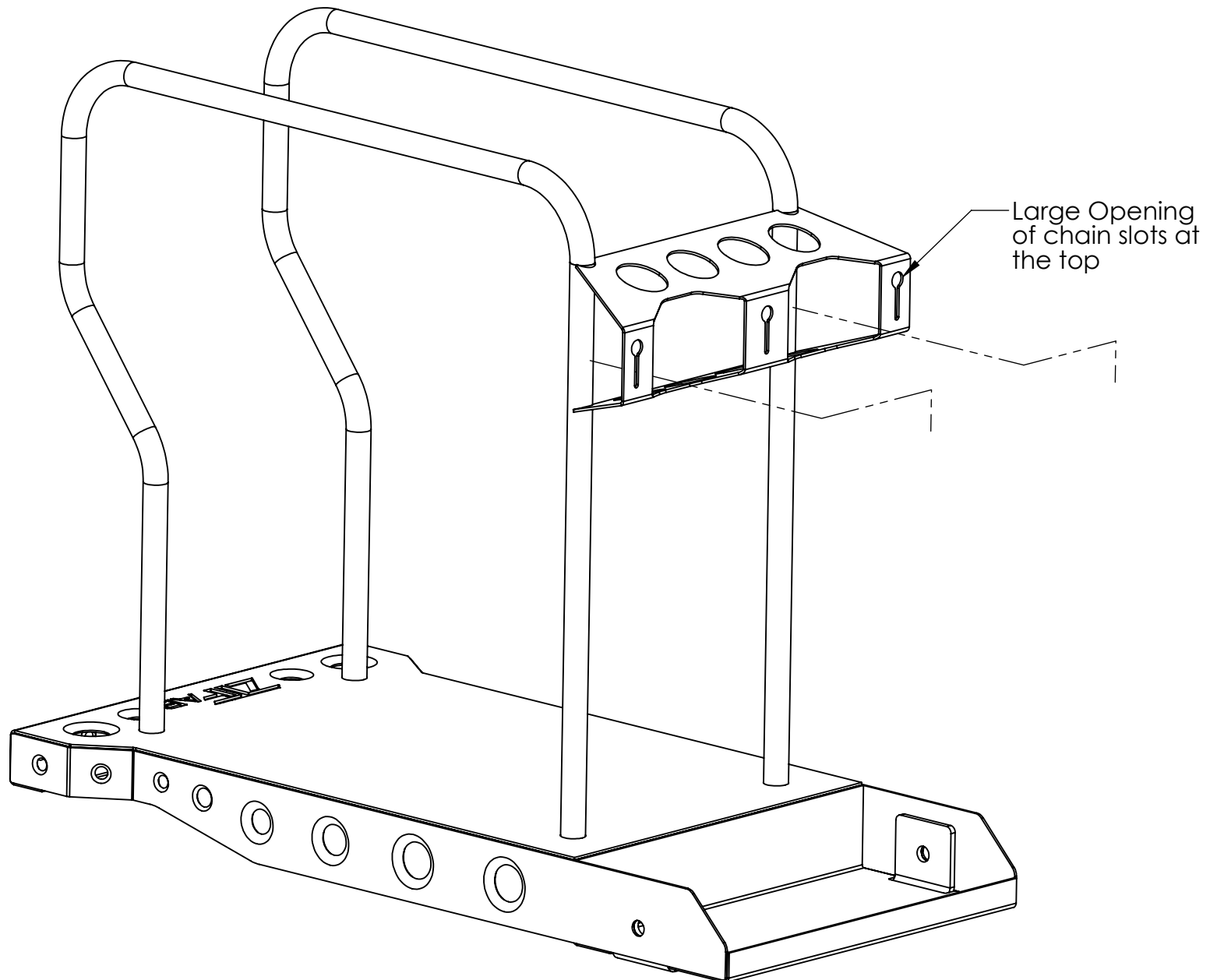

Step 7: Machine Mounts

Position the base of the machine mounts on the tubes. Make sure that the mounts are 90* to the tube and leaves ample room for cords, cables, hoses. Place the U-Brackets onto the bases and into their corresponding slots.

Once you have the first mount in position, tack it in place. Place the second mount on the tubes and position it far enough away so the welder can sit inside the mounts.

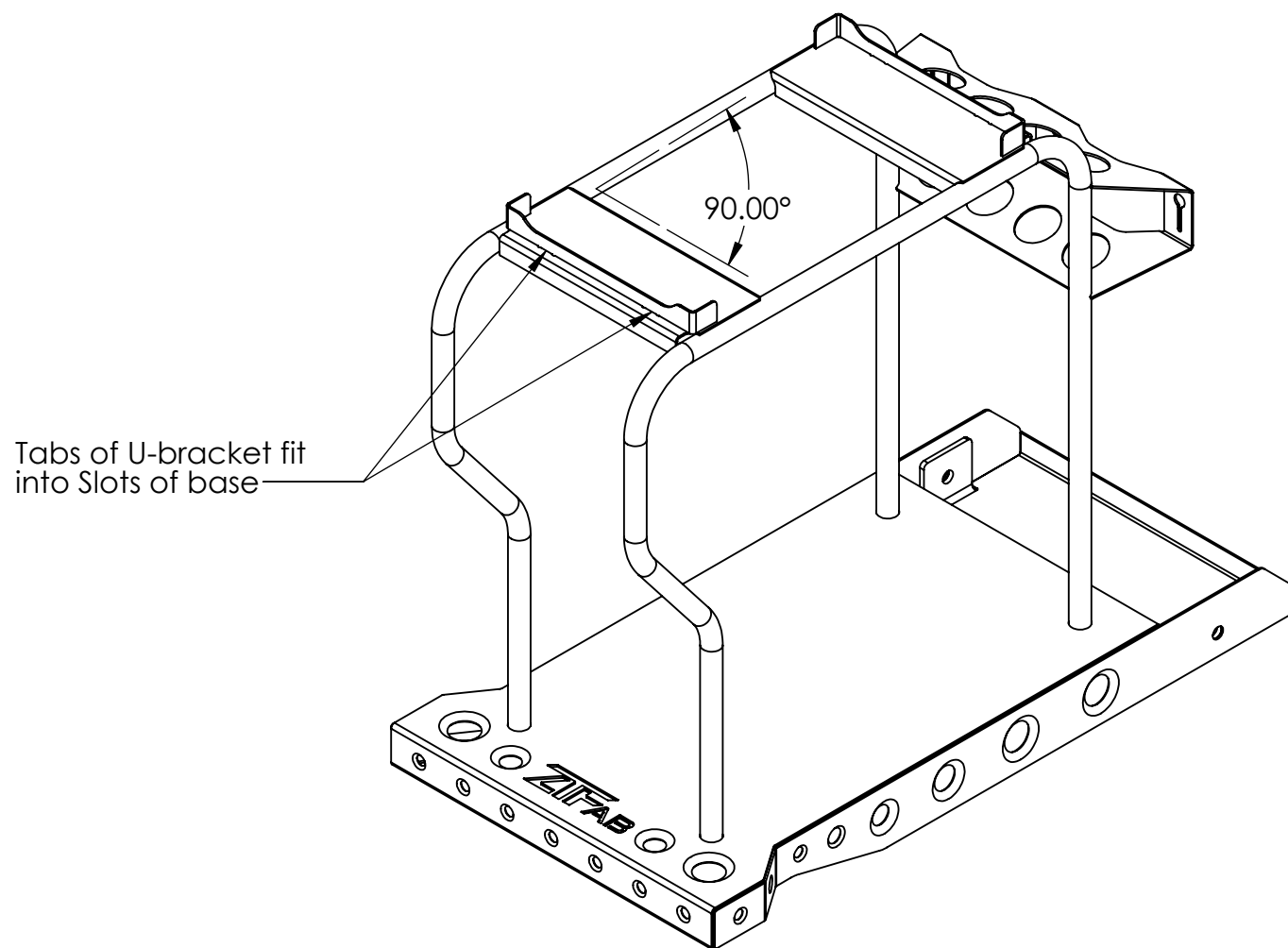

Step 8: Accessory Tubes

Place the accessory tubes on the handle tubes. Make sure the tubes are level. The height of the tubes is completely to your preference.

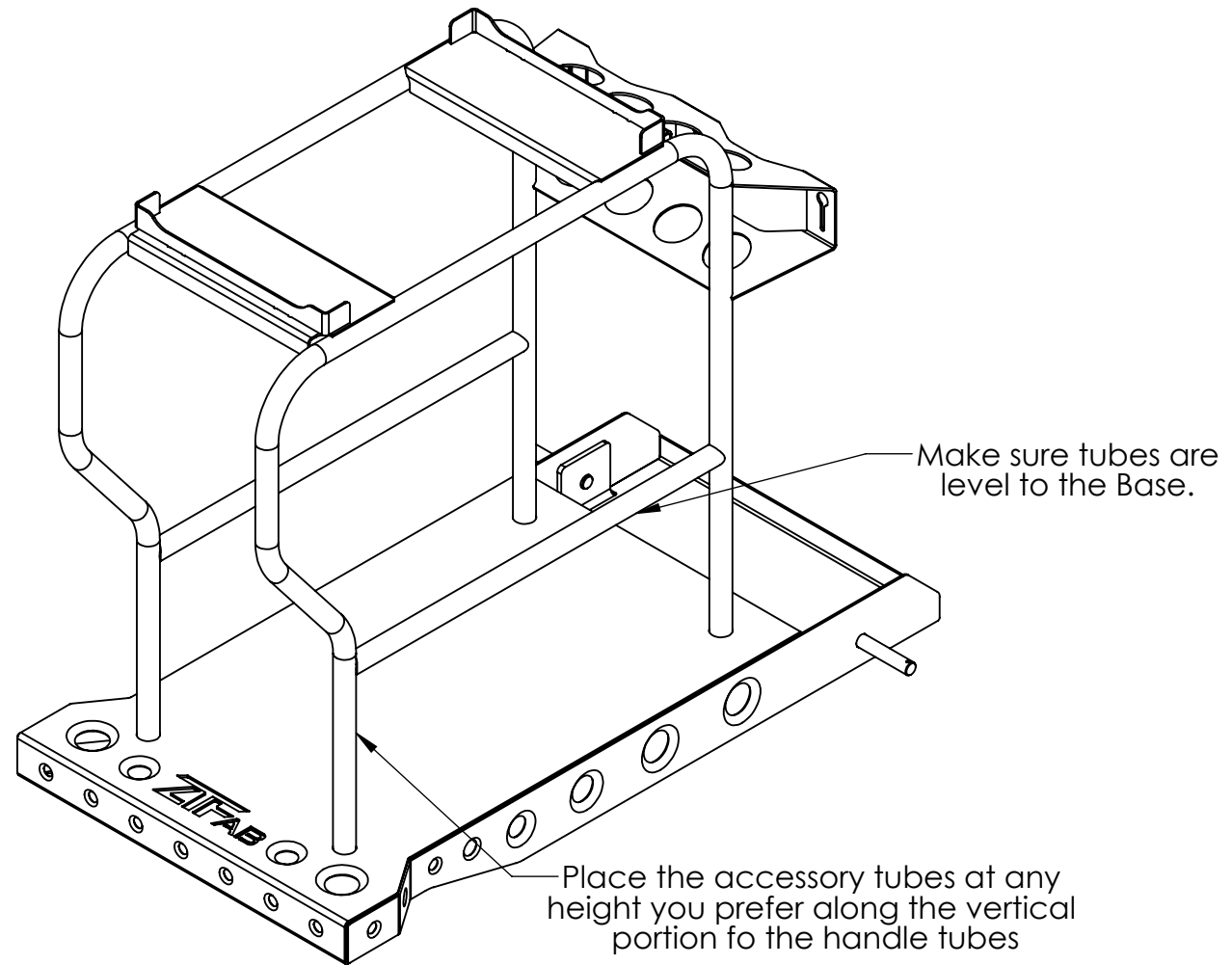

Step 9: Cord and Accessory hangers

Place the cord hangers and/or foot pedal holder on the tubes. The placement of these items is completely to your preference.

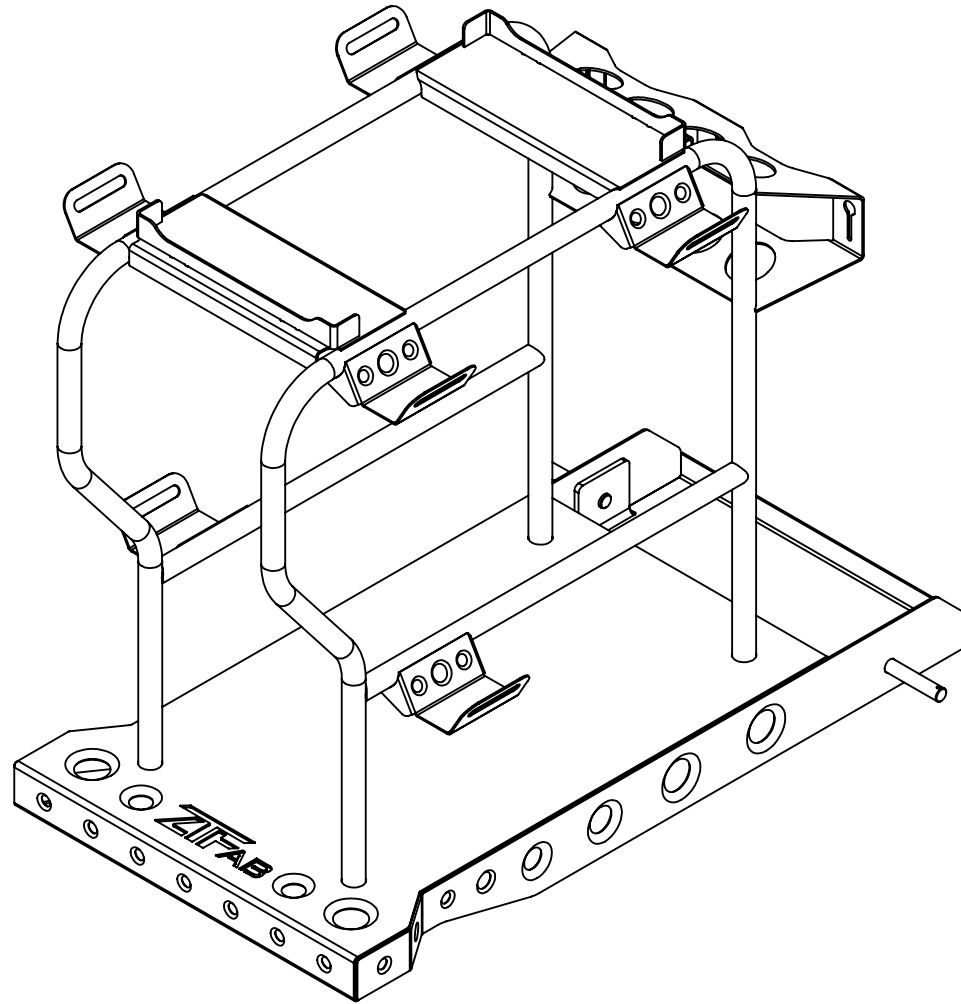

Step 10: Axle Shafts

Place the axle shaft through the sides of the base and into the axle bracket. The axle should protrude through the axle bracket 1/8"-1/4" depending on the wheel used. If necessary, use the wheel with any spacers or washers required to ensure proper depth.

Make sure the axles are parallel to the ground and 90° to the cart sides and tack in place. **DO NOT PLACE ANY TACK WELDS OR FINAL WELDS ON THE OUTSIDE OF THE AXLE SHAFTS.**

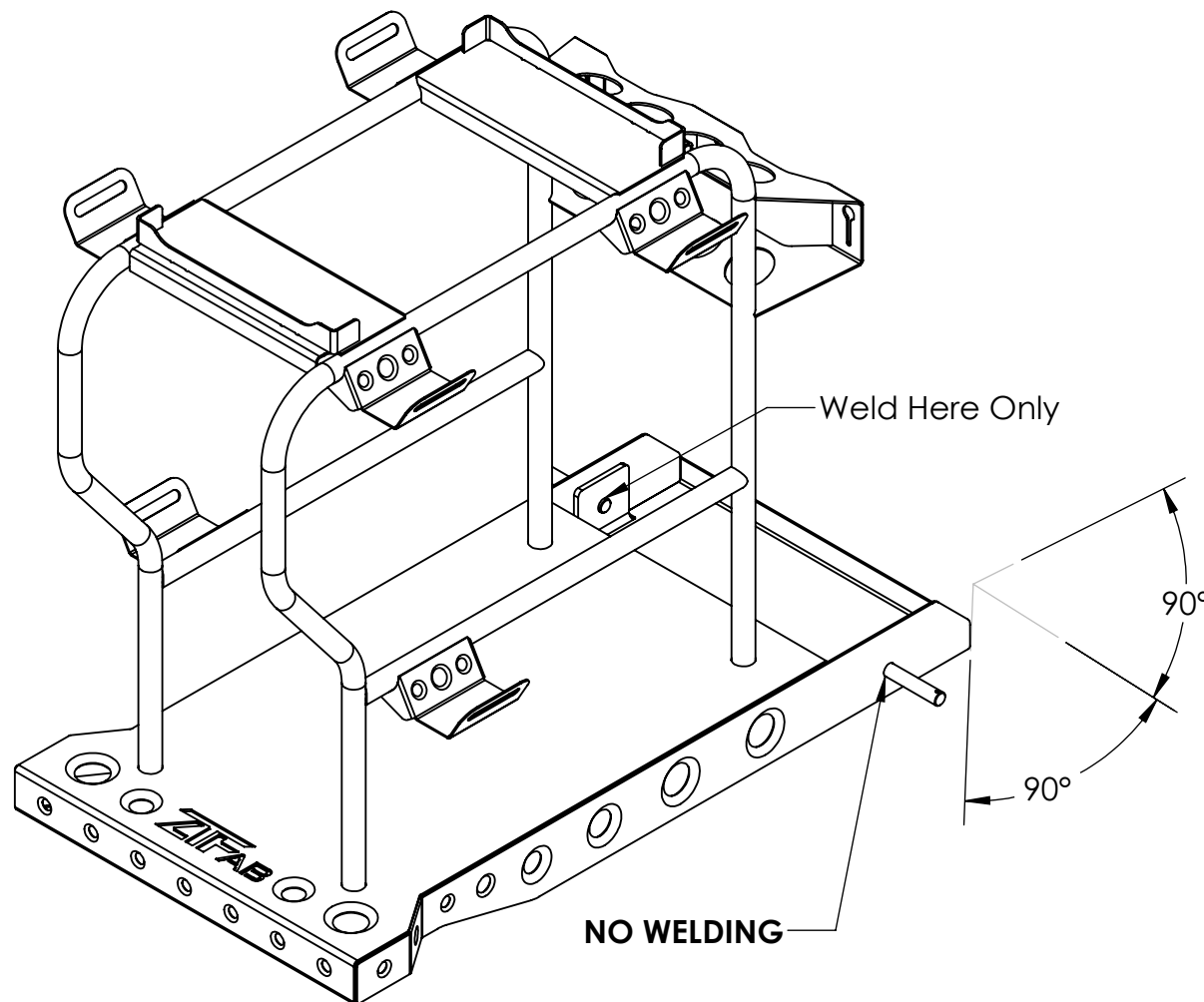

Step 11: Final Welding

Ensure that all brackets, tabs, and parts are securely tack welded in their proper locations. Complete all welds as necessary.

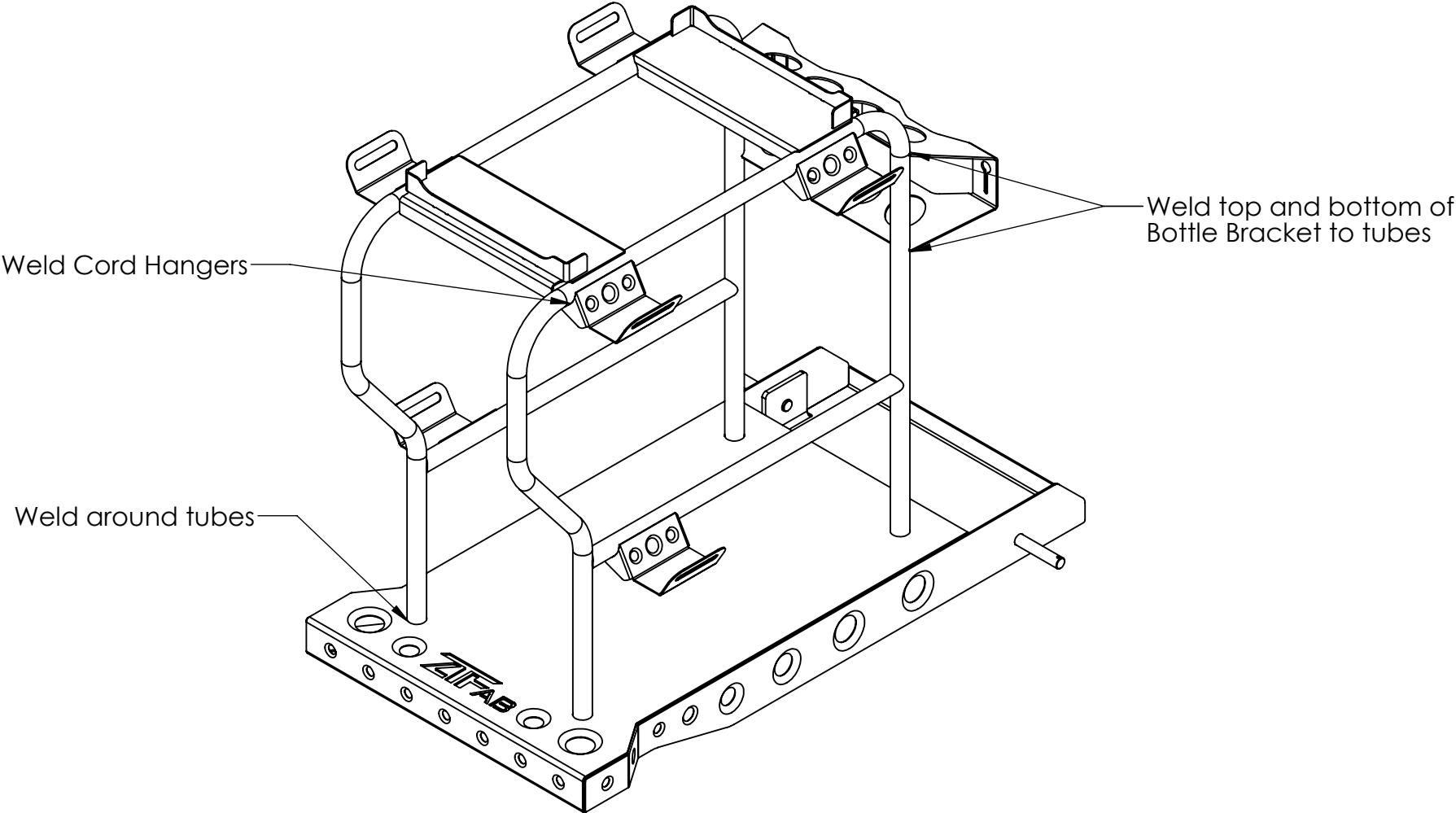

Step 12: Assembly

After you have test fit your welder, bottles, all accessories, and applied your preferred method of protection (i.e., paint, powder coat, etc) install the front casters and rear wheels with the supplied hardware. Attach the bottle chains to the bottle bracket by inserting the ends into the Key holes.

